



**MORE EXCITEMENT FROM AMF!**

# **SENSATIONAL PRICES 2022**

CLAMPING TECHNOLOGY FROM THE MARKET LEADER



**AMF "ZERO-POINT" CLAMPING SYSTEMS**

**MAGNETIC CLAMPING SYSTEMS**

**VACUUM CLAMPING SYSTEMS**

**PNEUMATIC CLAMPS**

**SINGLE AND MULTIPLE CLAMPING SYSTEMS**

**HOME OF  
CLAMPING**







until now € 3.761,-  
**NOW ONLY € 2.717,-**



#### 4-WAY CLAMPING STATION

Zero-point clamping station for setup-time-optimised clamping on machine tables with groove spacing of 63, 100 and 125 mm\*. Pitch spacing 200 mm.

Size K10.2, hydraulic – Holding force 4 x 25 kN

**ORDER NO. 559082 - ONLY € 2.717,-**

Size K10.3, pneumatic – Holding force 4 x 25 kN

**ORDER NO. 556118 - ONLY € 2.980,-**

Size K20\*, hydraulic – Holding force 4 x 55 kN

**ORDER NO. 561218 - ONLY € 3.434,-**

Size K20.3, pneumatic – Holding force 4 x 55 kN

**ORDER NO. 556119 - ONLY € 4.270,-**

\* Order no. 561218: Customer must make the hole pattern to fit the machine table.

until now € 5.327,-  
**NOW ONLY € 3.869,-**



#### 6-WAY CLAMPING STATION

Zero-point clamping station for setup-time-optimised clamping on machine tables with groove spacing of 63, 100 and 125 mm\*. Pitch spacing 200 mm.

Size K10.2, hydraulic – Holding force 6 x 25 kN

**ORDER NO. 559083 - ONLY € 3.869,-**

Size K10.3, pneumatic – Holding force 6 x 25 kN

**ORDER NO. 556122 - ONLY € 4.466,-**

Size K20\*, hydraulic – Holding force 6 x 55 kN

**ORDER NO. 561219 - ONLY € 4.995,-**

Size K20.3, pneumatic – Holding force 6 x 55 kN

**ORDER NO. 556123 - ONLY € 5.815,-**

\* Order no. 561219: Customer must make the hole pattern to fit the machine table.

INCLUDING **FREE** ACCESSORIES!



Illustration similar.  
 Composition of accessories  
 depending on design of the clamping station.

#### WITH SIZE K10.2

1 x quick-release coupling

#### WITH SIZE K10.3

1 x pneumatic hose,  
 1 x quick-release coupling and fittings

#### WITH SIZE K20

1 x quick-release coupling

#### WITH SIZE K20.3

1 x pneumatic hose,  
 1 x quick-release coupling and fittings



until now € 1.038,-  
**NOW ONLY € 562,-**



#### **PRESSURE INTENSIFIER**

Compact, air-pressure-operated pressure intensifier for single-acting hydraulic circuits.  
 The pressure intensifier is used for opening the hydraulic clamping stations.

**ORDER NO. 559084 - ONLY € 562,-**

until now € 204,-  
**NOW ONLY € 113,-**



#### **HYDRAULIC CONNECTION KIT**

Consisting of:  
 1 x hydraulic connecting tube, 1 x pressure gauge,  
 2 x straight pipe connections and screw-in flanges,  
 1 x T-bolt fitting and screw-on fitting,  
 2 x quick-release coupling sleeves and plugs,  
 2 x Cu sealing ring

**ORDER NO. 559085 - ONLY € 113,-**

until now € 772,-  
**NOW ONLY € 313,-**



#### **INTERCHANGEABLE PALLET**

made of high-strength aluminium.

Fits 4-way clamping station K10.2 / K10.3

**ORDER NO. 556120 - ONLY € 313,-**

Fits 4-way clamping station K20 / K20.3

**ORDER NO. 556121 - ONLY € 494,-**

Fits 6-way clamping station K10.2 / K10.3

**ORDER NO. 556124 - ONLY € 664,-**

Fits 6-way clamping station K20 / K20.3

**ORDER NO. 556125 - ONLY € 737,-**



until now € 292,-  
**NOW ONLY € 212,-**



### COMPLETE SET OF PULL-STUDS

Consisting of:

1 x Zero-point pull-studs, 1 x timing pull-stud,  
 4 x undersize pull-studs, 6 x engagement screws

Size K10 - M8

**ORDER NO. 563377 - ONLY € 212,-**

Size K20 - M12

**ORDER NO. 563378 - ONLY € 353,-**

until now € 325,-  
**NOW ONLY € 220,-**



### ADAPTER SET FOR K10 PULL-STUD

For reducing the mounting bore of the  
 K20 pull-stud to K10.

6 x Size K20-K10

**ORDER NO. 563379 - ONLY € 220,-**

until now € 1.082,-  
**NOW ONLY € 799,-**

### CLAMPING PALLET

Grid clamping pallet for flexible construction of the modular zero-point clamping system size K10 and K20 as well as of the block-clamping system M12. Including mounting bores for zero-point pull-stud on the bottom. Material: tempered steel.

Size 395 x 395 mm

**ORDER NO. 563477 - ONLY € 799,-**

Size 595 x 395 mm

**ORDER NO. 563478 - ONLY € 899,-**

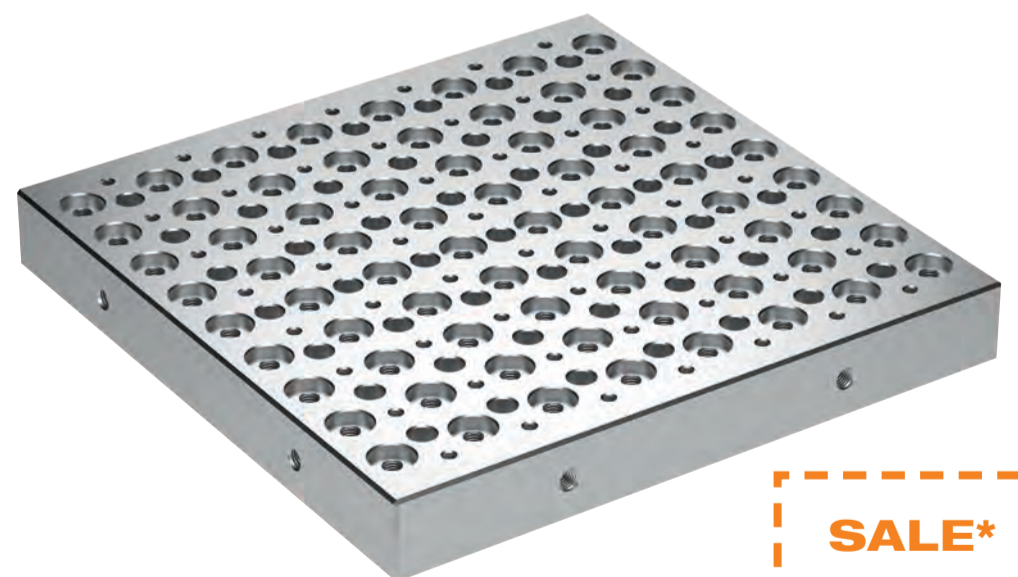

**SALE\***



until now € 2.035,-  
**NOW ONLY € 1.313,-**



### MULTIPLE CLAMPING SYSTEM

Clamping rail including clamping jaws and wedge clamps!  
 Existing mounting holes for pull-studs of the AMF "Zero-Point" clamping system.

Size 400 x 80 mm - for 2 workpieces

**ORDER NO. 556116 - ONLY € 1.313,-**

Size 600 x 80 mm - for 4 workpieces

**ORDER NO. 556117 - ONLY € 2.125,-**

### MECHANICAL COLLET

For clamping complex workpiece contours for 5-sided machining in the machine tool. The counterblock of the workpiece is milled into the collet attachment. Warp-free clamping is achieved through evenly applied clamping force.

Collet including body

**ORDER NO. 566122 - ONLY € 510,-**

Collet attachment

**ORDER NO. 566123 - ONLY € 106,-**

until now € 1.089,-  
**NOW ONLY € 510,-**



until now € 730,-  
**NOW ONLY € 399,-**



### CHAIN CLAMPING SET

For the clamping of mainly cylindrical parts such as valve bodies, flanges, pump housings, pistons, etc. Can be used on machine tables and on clamping pallets.

For slot 14, 16, 18

**ORDER NO. 566124 - ONLY € 399,-**

For slot 18, 20, 22, 24

**ORDER NO. 566125 - ONLY € 546,-**





until now € 5.268,-

**NOW ONLY € 2.442,-**

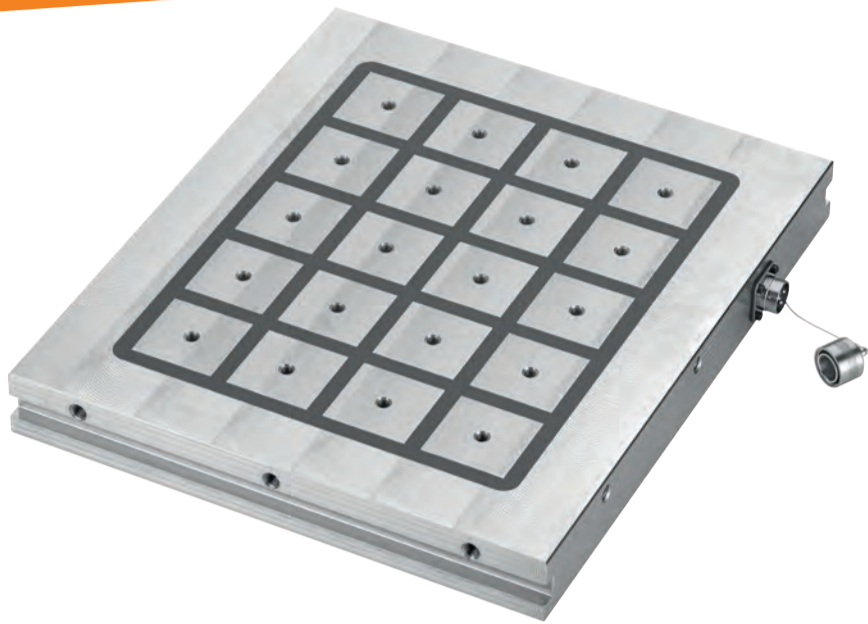

### MAGNETIC CLAMPING PLATE FOR MILLING

Square pole technology in monoblock design.  
For positioning, clamping and machining of magnetizable materials.

Size 390 x 330 mm – holding force 8 tonnes

**ORDER NO. 553197 - ONLY € 2.442,-**

Size 580 x 390 mm – holding force 16 tonnes

**ORDER NO. 553198 - ONLY € 3.350,-**

Size 780 x 390 mm – holding force 20 tonnes

**ORDER NO. 553199 - ONLY € 4.200,-**



INCLUDING CONTROL UNIT,  
HAND-HELD CONTROLLER  
AND POLE EXTENSION SET!  
**FREE!**

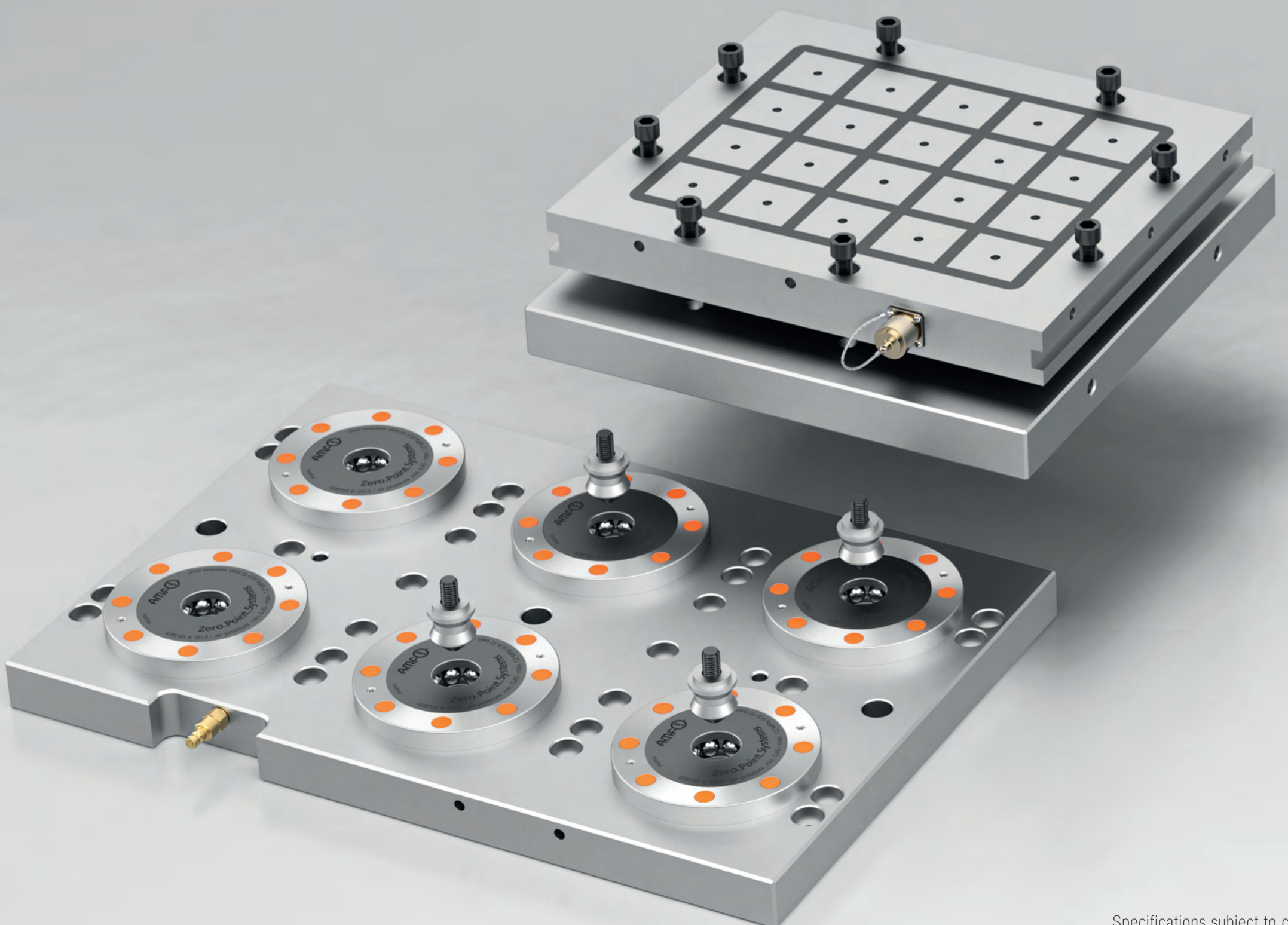



until now € 623,-  
**NOW ONLY € 293,-**



**VACUUM CLAMPING PLATE - BASIC LINE -**

The clamping plate can be operated using compressed air and the integrated venturi nozzle, or with an external vacuum pump.

Size 190 x 290 mm

**ORDER NO. 566126 - ONLY € 293,-**

Size 290 x 390 mm

**ORDER NO. 566127 - ONLY € 392,-**

Size 390 x 390 mm

**ORDER NO. 566128 - ONLY € 512,-**

Size 390 x 590 mm

**ORDER NO. 566129 - ONLY € 679,-**

until now € 251,-  
**NOW ONLY € 129,-**



**CONNECTING KIT FOR VENTURI NOZZLE**

Comprising:

- 1 x venturi nozzle, 1 x plug-in nipple,
- 1 x pneumatic hose 10 m

**ORDER NO. 566130 - ONLY € 129,-**

until now € 7,60  
**NOW ONLY € 2,95**



**RUBBER ADAPTER MAT**

Milling up to 2 mm deep into the adapter mat are not a problem.

Size 300 x 200 mm

**ORDER NO. 566131 - ONLY € 2,95**

Size 300 x 400 mm

**ORDER NO. 566132 - ONLY € 5,49**

Size 400 x 400 mm

**ORDER NO. 566133 - ONLY € 7,70**

Size 400 x 600 mm

**ORDER NO. 566134 - ONLY € 10,75**



until now € 226,-  
**NOW ONLY € 119,-**



**PNEUMATIC CLAMP**

with horizontal cylinder attachment. Double-acting.  
 With magnetic piston for end-position monitoring.

Size 01

**ORDER NO. 566135 - ONLY € 119,-**

Size 02

**ORDER NO. 566136 - ONLY € 129,-**

Size 03

**ORDER NO. 566137 - ONLY € 139,-**

Size 04

**ORDER NO. 566138 - ONLY € 189,-**

until now € 302,-  
**NOW ONLY € 163,-**



**PNEUMATIC CLAMP**

with vertical cylinder attachment. Double-acting.  
 With magnetic piston for end-position monitoring.

Size 02

**ORDER NO. 566139 - ONLY € 163,-**

Size 03

**ORDER NO. 566140 - ONLY € 181,-**

until now € 695,-  
**NOW ONLY € 399,-**



**HEAVY PNEUMATIC CLAMP**

with horizontal cylinder attachment. Double-acting.  
 With magnetic piston for end-position monitoring.

Size 04

**ORDER NO. 566152 - ONLY € 399,-**

until now € 600,-  
**NOW ONLY € 323,-**



**PNEUMATIC CLAMP**

Mini design in block version for clamping and gripping technology. High-strength aluminium, red anodised.  
 Magnetic piston for end-position monitoring.

Size 16

**ORDER NO. 566153 - ONLY € 323,-**



until now € 609,-  
**NOW ONLY € 313,-**

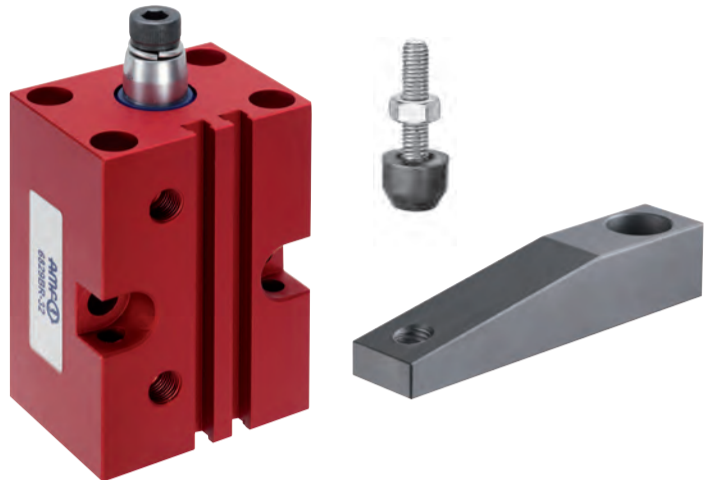

### PNEUMTIC SWING CLAMP

Block version. Double-acting. Including clamp arm and clamping screw. With magnetic piston for end-position monitoring.

Size 25, right-swivelling

**ORDER NO. 566146 - ONLY € 313,-**

Size 25, left-swivelling

**ORDER NO. 566689 - ONLY € 313,-**

Size 63, right-swivelling

**ORDER NO. 566147 - ONLY € 422,-**

Size 63, left-swivelling

**ORDER NO. 566692 - ONLY € 422,-**

until now € 413,-  
**NOW ONLY € 207,-**



**SALE\***

### PUSH-TYPE PNEUMATIC TOGGLE CLAMP

Thrust clamp. Double-acting.

With magnetic piston for end-position monitoring.

Size 05

**ORDER NO. 566148 - ONLY € 207,-**

Size 07

**ORDER NO. 566150 - ONLY € 280,-**

until now € 269,-  
**NOW ONLY € 96,-**



**SALE\***

### PNEUMATIC CLAMP

with vertical cylinder attachment. Double-acting. With magnetic piston for end-position monitoring.

Size 02

**ORDER NO. 566154 - ONLY € 96,-**

until now € 190,-  
**NOW ONLY € 94,-**

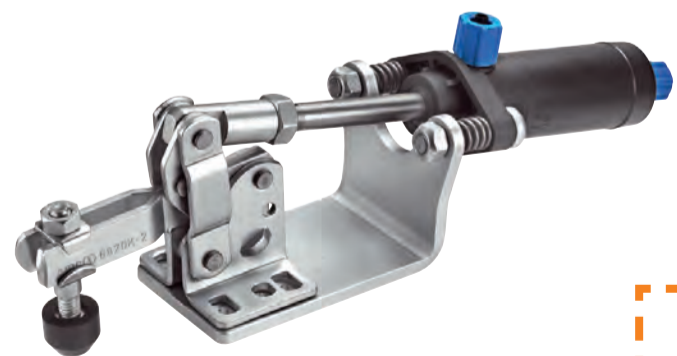

**SALE\***

### PNEUMATIC CLAMP

with horizontal cylinder attachment. Double-acting.

Size 02

**ORDER NO. 566157 - ONLY € 94,-**





### “ZERO-POINT” CLAMPING SYSTEM

The AMF “ZERO-POINT-SYSTEM” with its innovative technology ensures perfect clamping. The highly precise clamping modules have high draw-in, locking and holding force and are suited for the widest range of applications. Progress that pays off!



### HYDRAULIC CLAMPING SYSTEMS

The principle of hydraulic clamping technology and its consistent further development is the basis for an extensive product range that impresses users with its quality and inspires with its versatility. Practical day-to-day needs and solutions to them are the benchmark and driving force here.



### VACUUM CLAMPING SYSTEMS

Each workpiece is fastened to the clamping plate by a vacuum so that it can be machined from all sides without any damage. Particularly in the timber, plastic and NE metal industry flexible vacuum clamping systems contribute towards the increase of economic efficiency and productivity.



### MAGNETIC CLAMPING SYSTEMS

The force of the magnetic field serves as the basis of this innovative technology, which clamps the workpiece reliably for machining on 5 sides.

Surface quality and higher precision are the results of this unique combination of performance, safety and efficiency.



### WIRELESS SENSING SYSTEMS

The AMF wireless sensing system enables wireless and flexible sensor querying within the production environment. Transmitter units transmit the states detected by sensors wirelessly and in an energy-efficient manner using Bluetooth Low Energy 4.0. As the receiver, the gateway handles the communication between the sensor and the machine control.



### MARKING AND CLEANING TOOLS

The high economic efficiency of AMF products stems from their low procurement costs and long service life. The AMF markers ensure a high-quality, durable written type face without corrosion of the workpiece, and with the Cleaner products, the machine practically cleans itself.



### TOGGLE CLAMPS, MANUAL AND PNEUMATIC

Whether manual or pneumatic – the versatile AMF toggle clamps are fully functional even after years of use and achieve long-term rationalization success. Apart from favourable force and motion ratios, the entire product range offers easy handling in daily use.



### STANDARD CLAMPING ELEMENTS

Unique versatility distinguishes the extensive product range, which offers the optimum clamping element for any type of application. At the same time, the individual products meet the highest demands for quality and innovation. This results in clamping solutions that optimise processes and are convincing in practice.

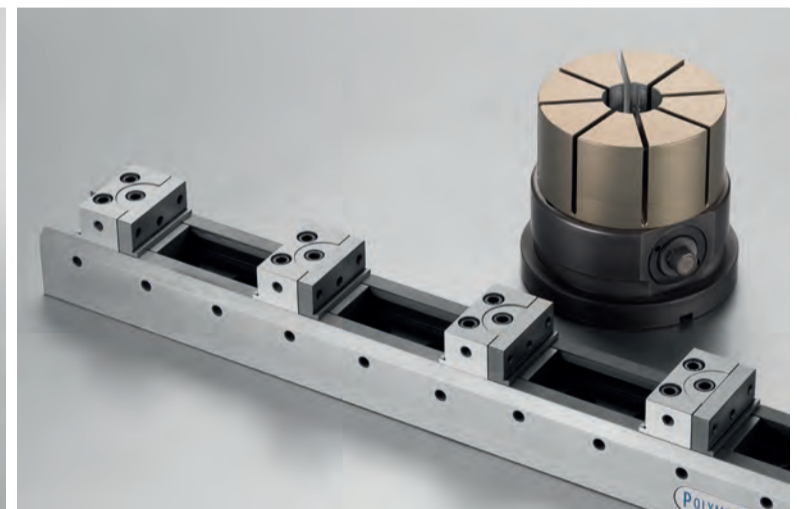

### SINGLE & MULTIPLE CLAMPING SYSTEMS

Ideal for smaller components. Precision vices and clamps for reliable clamping – even of complex external contours. The multiple clamping systems also achieve enormous time savings, which also permit clamping of multiple and different workpieces at the same time.